



ADDRESS

Corporate Office: D-73, Okhla Industrial Area, Phase – 1, New Delhi - 110020
Tel: 011-45729000 | Email: info@oysterbath.com

Regional Office:

Bangalore: 499 East End Main Road, 9th Block, East Jayanagar, Bangalore - 560069
Tel: 080-26645448, 26645447, Mob: +91 8884421000 | Email: bangalore@oysterbath.com

Kolkata: AA-47, 2nd Floor, Salt Lake, Kolkata - 700064
Mob: +91 8697980112 | Email: kolkata@oysterbath.com

Mumbai: 31-F Laxmi Industrial Estate, Road No. 1, Off Link Road, Andheri West, Mumbai - 400053
Mob: +91 9350597704, +91 8879088901, +91 8879088905 | Email: mumbaicare@oysterbath.com

Chennai: New No 30/19, Dr Ambedkar road, Kodambakkam, Opposite to HDFC bank, Chennai - 600024
Mob: +91 8939022291

Hydrabad: Mob: +



**2022 EDITION,
VOLUME -1.1**

Oyster[®]
Life Inside

ABOUT

Oyster, a brand name synonymous to excellence, reliability, creativity, and elite design, has nurtured our quality products since 2003, provides a widespread sales network, dependable customer care network, and honest commitment to our valued customers and trustworthy business partners.

Our aesthetically refined quality products are manufactured in our Ghaziabad, UP plant with full sincerity and commitment. We have carved a niche in manufacturing a wide range of wellness products like bathtubs, spas, enclosures, showers, panels, multisystem, and uPVC windows and doors. We will carry the same legacy in the years to come with our new range of products.

Oyster got its birth in 2003 and has now matured into a prominent quality brand, providing a mix and match of modernity of technology and artistic sensibilities in supplying the finest of windows and doors across India. Our creative innovation brings the likes of uPVC windows and doors in the most exquisite designs, colors, and textures.

Our artistically inventive designed uPVC windows and doors are a visual spectacle for the eyes and are appropriate to enlighten the charms of your households, offices, hospitals, hotels, restaurants, banquet halls and more.





MISSION

We at Oyster aim to delight our customers by providing innovative utility solutions for every home. uPVC or Unplasticised Polyvinylchloride being a standard material used in windows and doors, our mission is to give our customers benefits like good security, better insulation, low maintenance, ventilation, soundproof, fire retardant windows and doors.



VISION

Oyster's vision is to bedazzle the lifestyle of our customers with ecstasy, joy and happiness through our myriad designs of fabulous windows and doors. We understand the changing trends and technologies of our business and it inspires us in creating innovative products with extreme dexterity.

OYSTER FACTORY PLANT

-Ghaziabad, Uttar Pradesh

As Oyster is the leading manufacturer of wellness products in India, it manages its entire factory in the spirit of sustainability, development and continuous development.

It is not possible to create and develop innovative state-of-the-art products without a technically advanced production unit. Our production facilities have the necessary capacities and technologies to cover all market demands along with the preparation of brand new product lines.

We support development, increase productivity and motivate our employees and partners to participate in what will change the world of uPVC windows and doors in India.



LIFE INSIDE

2003 - Establishment of OYSTER

2005 - Addition of new product lines under 'wellness' category

2008 - Expansion of Factory

2010 - Crossed 300 mark dealer

2012 - Launched Brook Shower Series

2020 - Shower in new color variant launched, partnered with German company for uPVC

2021 - Launch of uPVC segment in the Indian market.

According to the expected course of action in the Indian market, our ambition is to expand Oyster and provide the best quality to our customers. uPVC windows and doors have witnessed significant growth during these years. The market has been growing majorly due to rising awareness amongst builders and consumers, rapid urbanization, growth in residential units, and increased adoption of eco-friendly and energy-conserving products. Oyster is willing to be a part of the country's needs and help to fulfill the country's demand for uPVC windows & doors.





Advantages OF OYSTER uPVC WINDOWS AND DOORS



● Durable

Our artistically designed and manufactured uPVC windows are durable par comfortable, promise longer life, and are resistant to environmental and climatic effects.

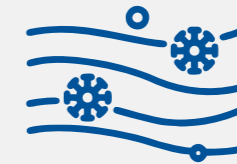

● Comfortable

Our product line of uPVC windows provides an efficient ventilation system and helps to maintain the temperature. It facilitates soothing airflow into the room and is noise resistant.



● Individual

The subdivision character depends on the choice of profile geometry ranging from the opening mechanism and windowpane subdivision to come up with a unique pattern to charm the looks of your room. Oyster is putting their best foot forward with uPVC window patterns to grace the indoors and outdoors look of your room.



● Versatile

These windows encompass diverse architectural designs with innovative and contemporary designs to gel with modern ethics. Replace your white or old-fashioned windows with a fancy window wrapped with wood-grain foil.

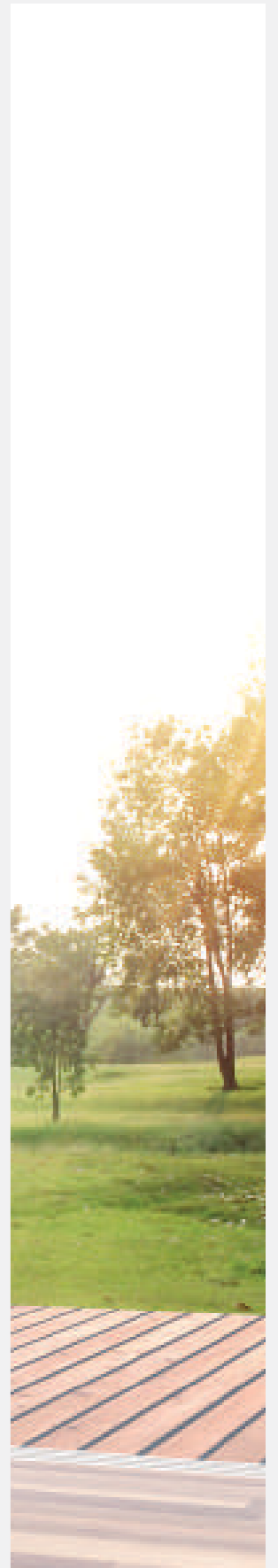

Innovation in Ventilation

Oyster[®]
Life Inside



We form the work for the world of windows in India

Oyster brings you exemplary unique doors and window systems! These will not just upgrade your interior's look but keep you safe from any climatic conditions. Oyster has modern uPVC systems for windows and doors.



Not All uPVC products are equal

Our latest-generation windows are not only attractive and sophisticated, but are also perfectly modelled with a number of modern smart functions to satisfy the most demanding technical and safety requirements.

OYSTER uPVC SYSTEMS

Our uPVC windows and doors are highly sophisticated to gel with the modern-day demands and developments. The latest technology has come a long way to demand sophisticated, geometrically perfect, attractive, and durable. Oyster has mastered and set up a new arena with high standard window designs to add more light with redder views.



OYSTER CADRADO

Highly elegant straight lines

The latest design and technical precision with the occurrence of complete concealment are highly recommended for contemporary or discreet design. Nowadays, Vinyl windows are the epitome of attraction to people's eyes because of their beautiful architecture.



OYSTER SEGURO

The safest window profiles

Oyster multi-level sealing and movement choices are powered with spectacular outcomes providing an uncompromising profile along with exceptional security and burglary-resistant. This offers transparency from the glass surface that opens up new design possibilities. Our new and innovative system offers a prosperous view without dismantling joints from the outside, the right-angled option will overlap the pleasant impression overall.



OYSTER EFICAR

The most environment-friendly and sustainable in the window industry

Highly environment-friendly and sustainable windows with a class of its own to rule the window industry!!!

A highly competent contour graced with armored elements is well-suited for windows. These frames demand maximum use of the material as they are shaped with intricate geometric designs.



CASEMENT SYSTEM Windows/Doors



CASEMENT SYSTEM

- Maximum possible ventilation while maintaining high noise reduction.
- We produce in any size and design according to the requirements of clients.
- Suitable for residential installations, such as bedrooms, living rooms and bathrooms, where they provide great flexibility with the possibility of ventilation.



 PANORAMIC VIEWS

 VENTILATION

 NOISE REDUCTION

 AIR AND WATER TIGHTNESS



SLIDING SYSTEM Windows/Doors



SLIDING SYSTEM

- The customary comfort in our new range of Oyster Eficar allows the panes to glide in both directions.
- Our new range of Oyster Eficar comes with a unique profile that not only save space but is suitable for all types of rooms and installations.
- It surprises with its flamboyant architectural creation which extends your vision to experience beautiful surroundings around you.
- Oyster's sliding windows comprises 2 tracks, 2.5 track, and 3 track system.



PANORAMIC VIEWS



VENTILATION



NOISE REDUCTION



AIR AND WATER TIGHTNESS

VILLA SYSTEM Windows



VILLA SYSTEM

- Windows of our Villa System have traditional grill and mesh options, equipped with dual seals and multi-chambered designs to prevent noise infiltration.
- Our energy-efficient Villa System provides an exclusive amalgamation of technique, traditionalism, and protection.
- Our scientifically crafted uPVC villa windows provide insulation from rain, dust, and pollution.
- It has cost-effective maintenance.



PANORAMIC VIEWS



VENTILATION



NOISE REDUCTION



AIR AND WATER TIGHTNESS



TILT & TURN SYSTEM Windows



TILT & TURN SYSTEM

- Our perfectly designed tilt and turn system form a perfect combination between the hinge and casement windows. You have the option to tilt it slightly or open the window for maximum ventilation.
- Our tilt and turn windows are well-suited for every bedroom and living room for the fresh breeze of air.
- Our perfectly designed tilt and turn system are very popular in Europe as it provides good insulation and ventilation properties.



 PANORAMIC VIEWS

 VENTILATION

 NOISE REDUCTION

 AIR AND WATER TIGHTNESS

TILT & SLIDE SYSTEM Windows/Doors



TILT & SLIDE SYSTEM

- Our perfectly designed tilt and slide system form a perfect combination between the tilt and slide window. You have the option to tilt it slightly or open the window for maximum ventilation.
- The movement of sashes from left to right and vice versa offers optimum utilization of available spaces.
- Comes in various color and designs with easy locking and hardware options.
- Our range of products amazes you with a wide range of colors, design and offer trouble-free locking and hardware options.

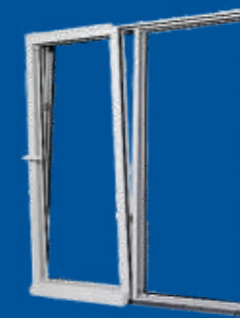

PANORAMIC VIEWS



VENTILATION



NOISE REDUCTION



AIR AND WATER TIGHTNESS



LIFT & SLIDE SYSTEM

Doors



LIFT & SLIDE SYSTEM

- Our splendid lift and slide system provide exquisite panoramic views with divider fewer glass panes.
- It offers enhanced security with superior insulation.
- Oyster offers advanced lift and slide technology that appreciably connects inside with outside through sliding panels with the provision of heavy-duty hardware that prevents stoppage of slider panel midway.

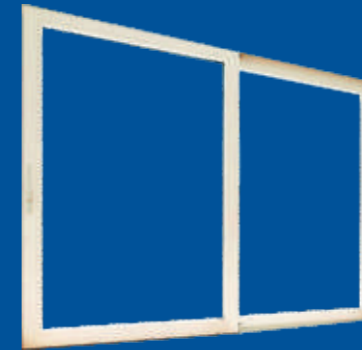

 PANORAMIC VIEWS

 VENTILATION

 NOISE REDUCTION

 AIR AND WATER TIGHTNESS



SLIDING FOLDING SYSTEM

Windows/Doors



SLIDING FOLDING SYSTEM

- Our Sliding Folding System in windows and doors is architectural marvels as it saves more space than traditional windows and doors.
- Our space-saving system allows you to draw a line between indoors and outdoors. Its well-conceived intricate patterns, slim panels clubbed with magnified glass area offer crystal clear views of the outdoors.
- Our uniquely designed Sliding Folding Systems in doors and windows are energy efficient. It works prolifically as good insulator to keep your home warm during winters and cool during summers.
- It is user-friendly in nature and can be effortlessly removed, as per the needs and requirements of the customer.



 PANORAMIC VIEWS

 VENTILATION

 NOISE REDUCTION

 AIR AND WATER TIGHTNESS



VERTICAL SLIDING SYSTEM

Windows



VERTICAL SLIDING SYSTEM

- We offer user-friendly vertical sliders which are artistically carved to complement as well as enhance the looks of your house, both from inside and outside.
- Our meticulously crafted vertical sliders offer a wide range of safety features. It will not only enhance the looks of your house but will also upgrade your styling quotient to a new high.
- Easy cleaning is ensured by the lower vertically tilting window sash.



PANORAMIC VIEWS



VENTILATION



NOISE REDUCTION



AIR AND WATER TIGHTNESS



ARCH SYSTEM

Windows/Doors



ARCH SYSTEM

- Ideal for advanced locking and security system along with a robust frame.
- Multi-chambered to diminish heat loss and improve thermal performance.
- Double/triple glazing assures excellent energy performance.
- Arch system windows are designed semi-round.
- You will get a unique atmosphere from classic rectangular windows and walls with our arched windows, which create a unique and contrasting impression.



 PANORAMIC VIEWS

 VENTILATION

 NOISE REDUCTION

 AIR AND WATER TIGHTNESS



BAY WINDOW SYSTEM

Windows/Doors



BAY WINDOW SYSTEM

- Oyster's elegantly designed bay window system is a collection of three or more windows in an angular formation.
- This technically refined window system converts regular house corners into spaces for relaxation.
- The well-crafted angular formation given to this window system is specifically designed to provide extreme comfort in all weather conditions.

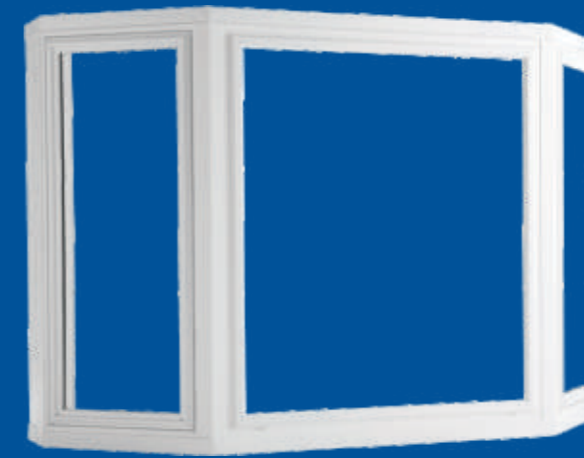

PANORAMIC VIEWS



VENTILATION



NOISE REDUCTION



AIR AND WATER TIGHTNESS



LOUVER SHUTTER SYSTEM

Windows/Doors



LOUVER SHUTTER SYSTEM

- Poly-fleece edges protect your house from dust, rain, sweep drafts and prevent unpleasant sharp sun.
- The combined handle allows for comfortable and compact operation.
- A centuries-old classic and secure touch protects which looks great.
- Extensive customization options prove best solution to ventilate bathrooms and small rooms.



PANORAMIC VIEWS



VENTILATION



NOISE REDUCTION



AIR AND WATER TIGHTNESS



uPVC WINDOW AND DOOR PROFILE



Oyster includes modern profile systems like 39, 44, 60 and 64 mm series profiles for both sliding and casement series, having a number of wood-grain foiling windows along with deep primary insulation and colour.



**CASEMENT WINDOWS & DOORS
PROFILE WITH SINGLE GLAZING**

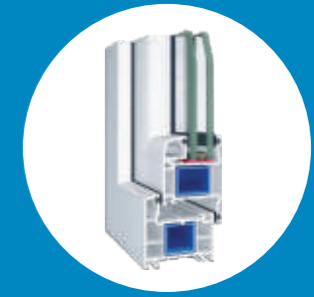

**CASEMENT WINDOWS & DOORS PROFILE
WITH DOUBLE GLAZED UNIT GLASS**

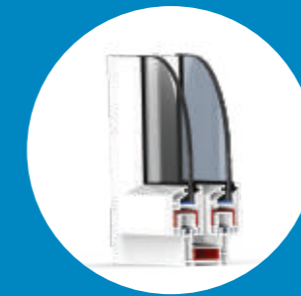

**2 TRACK SLIDING WINDOWS & DOORS
PROFILE WITH SINGLE GLAZING**



**2.5 TRACK, 2 SLIDING PANEL & MESH WINDOWS
& DOORS PROFILE WITH SINGLE GLAZING**



**3 TRACK, 3 SLIDING PANEL, WINDOWS
& DOORS PROFILE WITH SINGLE GLAZING**



**TWO TRACK SLIDING WINDOWS & DOORS
PROFILE WITH DOUBLE GLAZED UNIT GLASS**

GLASS PROFILES

Among all the different kinds of glasses available, one ought to choose the best glass, consisting of Heat Reduction, Sound Reduction & Safety. Our windowpanes are designed to fit glasses from 4mm thickness to 30 mm.

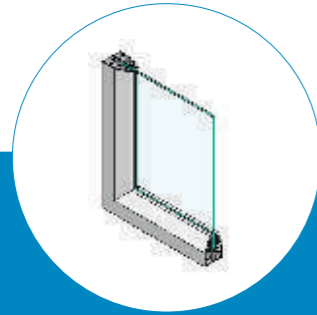

SINGLE GLAZED

Single Glazed windows are beautifully carved out from a single pane of glass. The pane is designed to be sized between 4mm and 12mm in thickness.

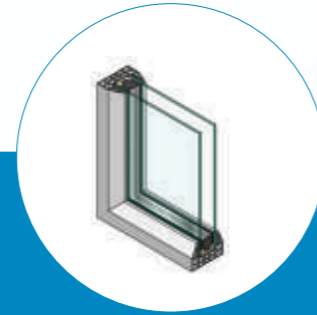

DOUBLE GLAZED

A Double Glazed Unit is crafted using the sequence of two panes of glass parted by a vacuum, air, or argon gas. The pane of glass will be sized approximately between 20mm and 30mm in thickness.



LAMINATED GLASS

Laminated Glass comprises two or more glass permanently bonded together with one or more layers of polyvinyl butyral (P V B). It is specifically used to enhance the safety of houses. In case of breakage, the glass parts are likely to stick to the plastic (PVB) layer.



FROSTED GLASS

Frosted Glass is purposely used when privacy is a priority. It allows light to pass through without a clear view. Frosted glass is fashioned by sandblasting or acid etching float glass.

FIXTURES OF GLASS

DECOR FOILS

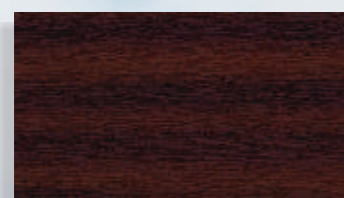

Mahogany

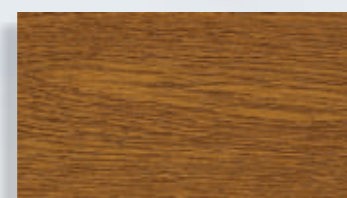

Golden Oak

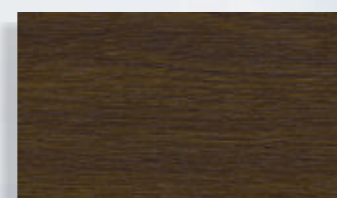

Rustic Oak

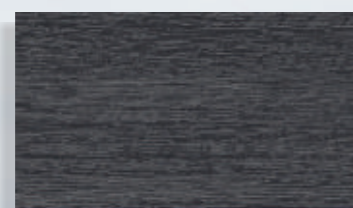

Anthracite Grey

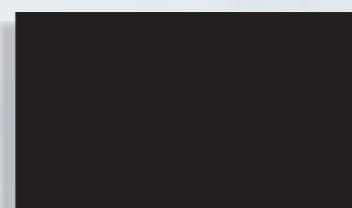

Black

“

“Oyster has been one of the pioneering, innovative, and reliable brand names in the thriving industry of bathroom wares and fixtures for years. Now, they have successfully ventured into an arena of stylish and inventive windows and doors. It will be “value for money” if you trust their products and make them a significant part of your lifestyle. Do adorn your house and convert every corner of it with their wide range of windows and doors, which are at par with world standards. Oyster is a brand name that ensures comfort and safety, with a promise to deliver you the best in the business!!!”

”



INSTALLATION & SERVICES

